

SÉRIE 5200
FEUILLE D'INSTALLATION
5200 SERIES
INSTALLATION SHEET

1. Installation

1. Appuyer et coller le ruban DEL (suivre les guides 10 mm ou 14 mm) sur le rail.

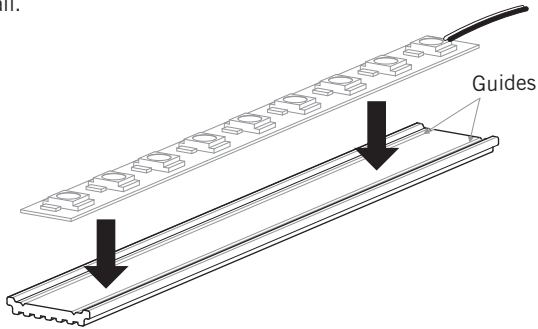

2. Glisser le rail à l'intérieur de la barre profilée.

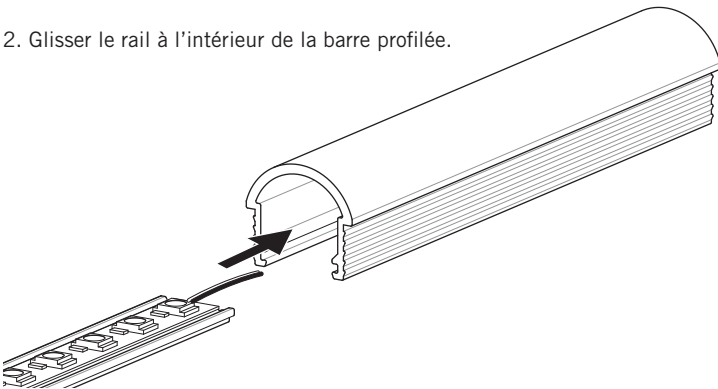

Safe, Fast and Easy to install with the E2LED POWER
Installation simple et rapide avec le système de connexion
E2LED POWER



1. Installation

1. Press and glue the LED Strip Tape onto the rail (follow 10 mm or 14 mm guides).

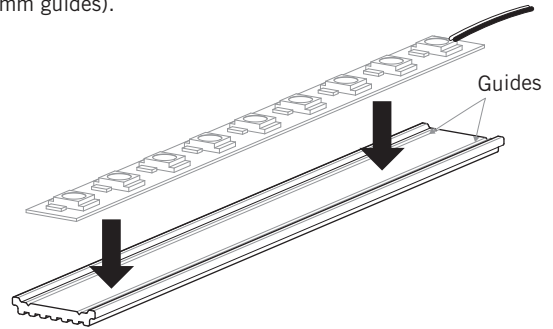

2. Slide the rail into the profiled bar.

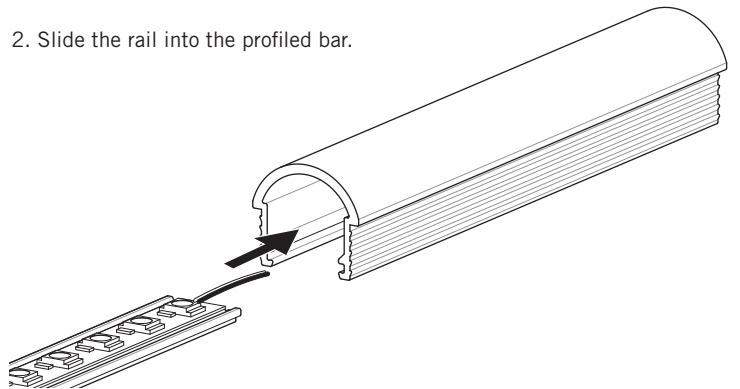

1. Installation

3. Mettre le luminaire en place.

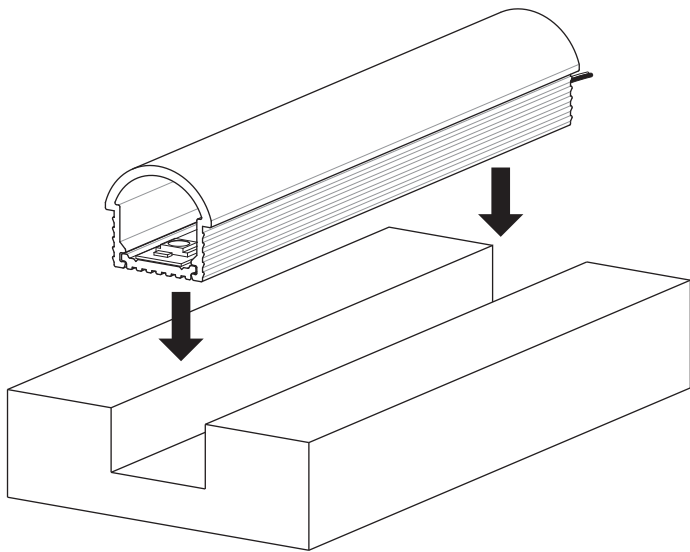

1. Installation

3. Clip the rail into place.

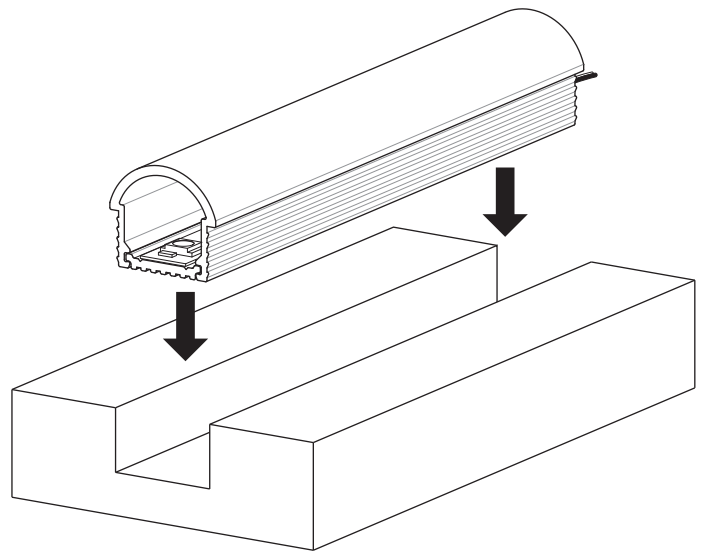

Mise en garde

1. Utiliser seulement des composants Certifiées Classe 2 n'excédant pas 30VCC ou 15VAC lors d'une installation dans un endroit mouillé ou 60VCC ou 42.4V ca maximum lors d'une installation dans un endroit sec ou humide.
2. Ne pas dépasser 5 ampères pour respecter les normes classe 2.

CLASSE
2

100W
MAX

4 AMP MAX
↓ 24V

5 AMP MAX
↓ 12V



Warning

1. Use only Class 2 rated components not exceeding 30VDC or 15VAC when installing the outline lighting in wet locations or 60VDC or 42.4V peak ac when installing the outline lighting in a dry or damp location.
2. Do not go over 5 amps to match class 2 requirements.

CLASS
2

100W
MAX

4 AMP MAX
↓ 24V

5 AMP MAX
↓ 12V